



PPUH AUTO-HAK S. J.

Produkcja Zaczepów Kulowych
Henryk & Zbigniew Nejman
76-200 SŁUPSK ul. Słoneczna 16K
tel/fax (059) 8-414-414; 8-414-413
E-mail: office@autohak.com.pl
www.autohak.com.pl

Towing hitch (without electrical set)

Class: **A50-X** Cat. no. **E39A**

Designed for:

Manufacturer: **OPEL**

Model: **COMBO**

Type: **C**

produced since 09.2001 till 2011

Technical data:

maximum D-value: **7,49 kN**

maximum trailer weight: **1200 kg**

maximum vertical cup mass: **50 kg**

Approval number according to Directive 94/20/EC: e20*94/20*1075*00

Foreword

This towing hitch is designed according to rules of safety traffic regulations. The towing hitch is a safety component and can be install only by qualified personnel. Any alteration or conversion of the towing hitch is prohibited and would lead to cancellation of design certification. Remove insulating compound and underseal from vehicle (if present) in the areas of the matting surfaces of the towing hitch.

The vehicle manufacturer's specifications regarding trailer load and max. vertical cup mass are decisive for driving whereat values for the towing hitch cannot be exceeded.

D-value formula:

$$\frac{\text{Max trailer weight [kg]} \times \text{Max vehicle weight [kg]}}{\text{Max trailer weight [kg]} + \text{Max vehicle weight [kg]}} \times \frac{9,81}{1000} = D \text{ [kN]}$$

FITTING INSTRUCTION

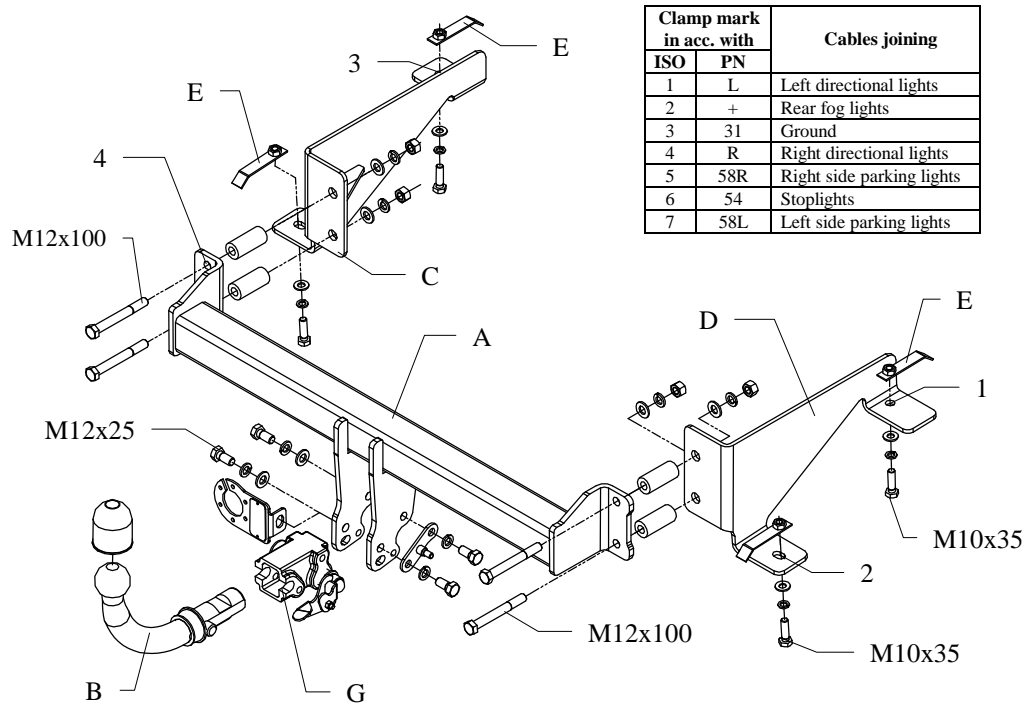

- Reassemble the aluminium support.
- Position the element (pos. C) to the car frame.
- Left side- fix using M10x35mm with special nut M10 (pos. E), which should be slide through the elongated holes (holes pos. 3 and 4 should match with original holes).
- Right side- do the same what on the left side after drilling hole $\varnothing 11$ through hole (pos. 1) and element (pos. D).
- Position the element (pos. A) to the rear panel and fix it through the slided spacers and elements (pos. C and D) using bolts M12x100mm .
- Reassemble the bumper after cut out its fragment (see fig. 2).
- Tighten all nuts and bolts according to the torque shown in the table.
- Fix body of the automat (pos. G) and the socket plate using bolts M12x25mm from accessories. Place tow-ball (pos. B) according to supplied instruction.
- Connect to the electric wires according to the instructions of the car.
- Complete the paint cover of towbar (during the mounting paint cover could be destroyed).

Torque settings for nuts and bolts (8,8):

M6 - 11 Nm	M8 - 25 Nm	M10 - 50 Nm
M12 - 87 Nm	M14 - 138 Nm	M16 - 210 Nm

NOTE

After install the towbar you should get adequate note in registration book (at authorised service station). The car should be equipped with:

- Indicators
- Tow mirrors

After 1000km of exploitation check all bolts and nuts. The ball of towbar must be always kept clear and conserve with a grease.

The towbar can be used in the following car:

OPEL COMBO C produced since 09.2001 till 2011, catalogue number **E39A**

Max trailers dimensions- 1200 kg

Max. Vertical mass- 50 kg

From manufacturer

Thank you for buying our product. Their reliability has been confirmed in many tests. Reliability of towbar depends also on correct assembly and right operation. For this reasons we kindly ask to read carefully this instruction and apply to hints.

The towbar should be installed in points described by a car producer.

The instruction of the assembly

- Disassemble the bumper and aluminium support.
- Drill the holes $\varnothing 25$ mm in the rear panel (holes are factory marked).
- Put the spacers L =56 mm to the drilled holes.

Fig. 2 Cut out of the bumper

