

FITTING INSTRUCTION

Clamp mark in acc. with		Cables joining
ISO	PN	
1	L	Left directional lights
2	+	Rear fog lights
3	31	Ground
4	R	Right directional lights
5	58R	Right side parking lights
6	54	Stoplights
7	58L	Left side parking lights

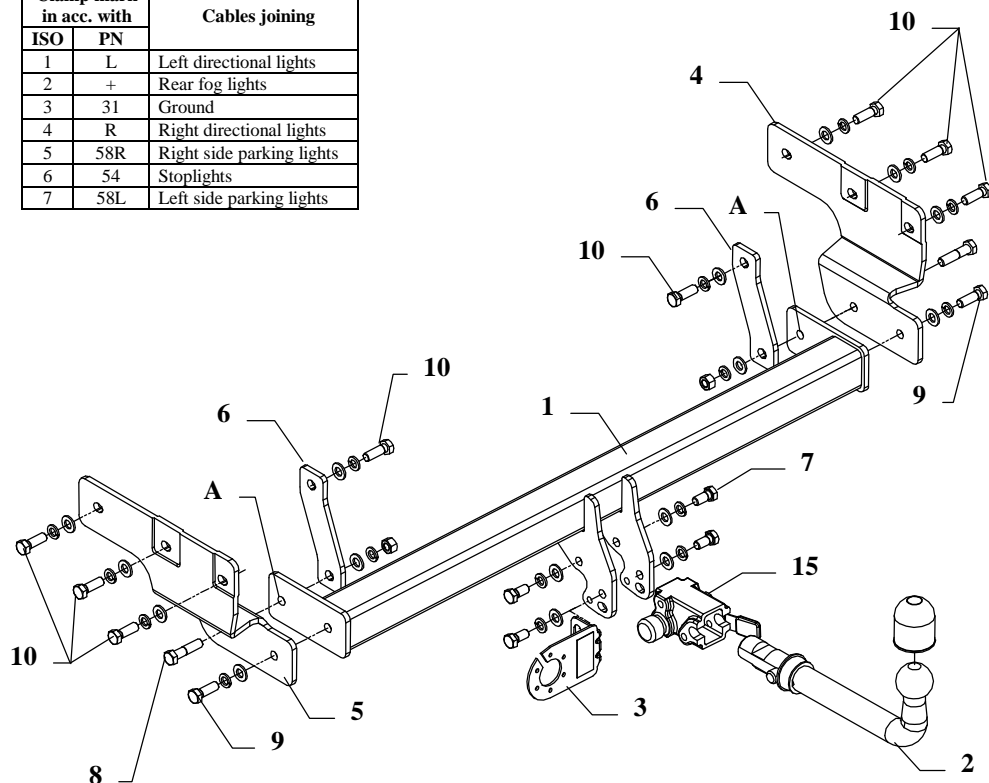

This towbar is designed to assembly in following cars:
MITSUBISHI PININ 5 doors, produced since 2000, catalogue no. **Z26A**
 and is prepared to tow trailers max total weight **1500kg** and max vertical load **75 kg**.

From manufacturer

Thank you for buying our product. Their reliability has been confirmed in many tests. Reliability of towbar depends also on correct assembly and right operation. For this reasons we kindly ask to read carefully this instruction and apply to hints.

The towbar should be install in points described by a car producer.

The instruction of the assembly

1. Unscrew bolts of the towing eye from the left chassis member, and then mount loosely bracket (pos. 5) with bolts M12x1,25x40mm (pos. 10).
2. Mount loosely the towbar bracket (pos. 4) to the right chassis member with bolts M12x1,25x40mm (pos. 10).
3. Slide the main bar of the towbar (pos. 1) between brackets (pos. 4 and 5) and fix it with bolts M12 as shown a sketch.
4. Fix fish-plates (pos. 6) to inside the chassis members through holes – pos. A (see the sketch)
5. Fix body of the automat (pos. 15) and the socket plate (pos. 3) using bolts M12x25mm (pos. 7) from accessories. Place tow-ball (pos. 2) according to supplied instruction.
6. Tighten all nuts and bolts according to the torque shown in the table.
7. Connect to the electric wires according to the instructions of the car.
8. Complete the paint cover of towbar (during the mounting paint cover could be destroyed).

Torque settings for nuts and bolts (8,8):	
M 8 - 25 Nm	M 10 - 55 Nm
M 12 - 85 Nm	M 14 - 135 Nm









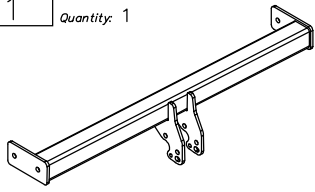
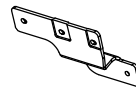

NOTE

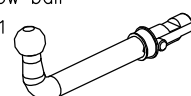
After install the towbar you should get adequate note in registration book (at authorised service station).The car should be equipped with:

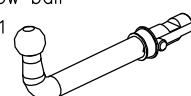
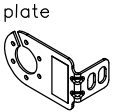
- Indicators
- Tow mirrors

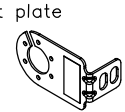
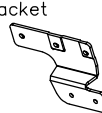
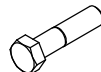
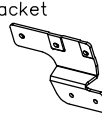
After 1000km check all bolts and nuts. The ball of towbar must be always kept clear and conserve with a grease.

Towbar accessories:

Pos. 1 Name: Main bar Quantity: 1	Pos. 5 Name: Left bracket Quantity: 1	Pos. 11 Name: Nut 8 B Quantity: 2 Dim.: M12
		
Pos. 2 Name: Tow ball Quantity: 1	Pos. 6 Name: Fish-plate Quantity: 2	Pos. 12 Name: Plain washer Quantity: 16 Dim.: Ø 13 mm
		
Pos. 3 Name: Socket plate Quantity: 1	Pos. 7 Name: Bolt 8,8 B Quantity: 4 Dim.: M12x25mm	Pos. 13 Name: Spring washer Quantity: 16 Dim.: Ø 12,2 mm
		
Pos. 4 Name: Right bracket Quantity: 1	Pos. 8 Name: Bolt 8,8 B Quantity: 2 Dim.: M12x50mm	Pos. 14 Name: Ball cover Quantity: 1
		
Pos. 10 Name: Bolt 8,8 B Quantity: 8 Dim.: M12x1,25x35mm	Pos. 9 Name: Bolt 8,8 B Quantity: 2 Dim.: M12x35mm	Pos. 15 Name: Body of the automat Quantity: 1
		
	Pos. 16 Name: Body plug Quantity: 1	



PPUH AUTO-HAK S. J.

Produkcja Haków Holowniczych
Henryk & Zbigniew Nejman
76-200 SŁUPSK ul. Słoneczna 16K
tel/fax (059) 8-414-414; 8-414-413
E-mail: office@autohak.com.pl
www.autohak.com.pl

Towing hitch (without electrical set)

Class: **A50-X** Cat. no. **Z26A**

Designed for:

Manufacturer: **MITSUBISHI**

Model: **PININ**

Type: **5doors**

produced since 2000

Technical data:

D-value: 8,10 kN

maximum trailer weight: **1500 kg**

maximum vertical cup load: **75 kg**

Approval number according to Directive 94/20/EC: e20*94/20*1039*00

Foreword

This towbar is designed according to rules of safety traffic regulations. The towing hitch is a safety component and can be install only by qualified personnel. Any alteration or conversion of the towing hitch is prohibited and would lead to cancellation of design certification. Remove insulating compound and underseal from vehicle (if present) in the area of the matting surfaces of the towing hitch.

The vehicle manufacturer's specifications regarding trailer load and max. vertical cup load are decisive for driving, and values for the towing hitch cannot be exceeded.

D-value formula:

$$\frac{\text{Max trailer weight [kg]} \times \text{Max vehicle weight [kg]}}{\text{Max trailer weight [kg]} + \text{Max vehicle weight [kg]}} \times \frac{9,81}{1000} = D \text{ [kN]}$$